

Revisions			
Rev	Description	Date	Initials
B	Updated drawing from old cad program	11/17/2010	TPA
C	Updated drawing to match actual mold features and dimension	3/26/2014	DVK

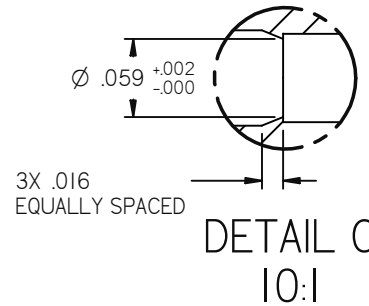
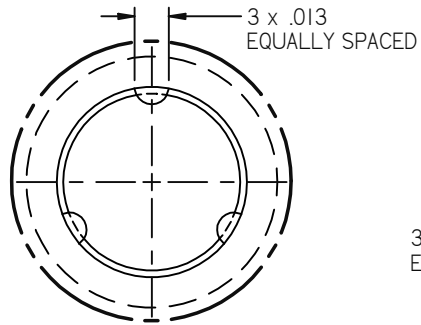
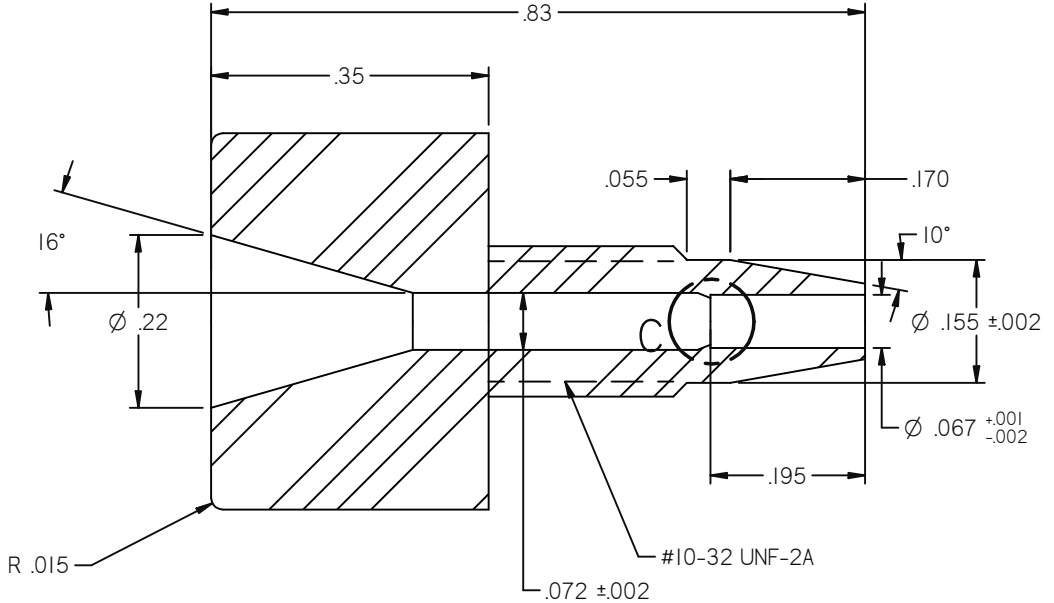
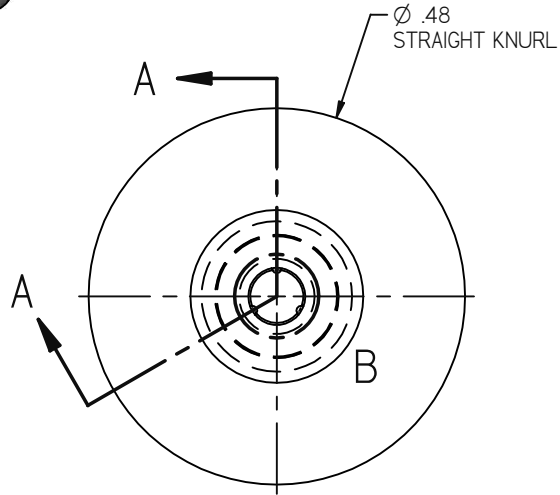
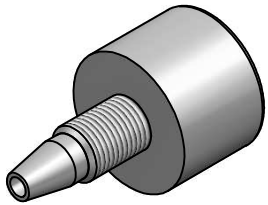

- NOTES:
1. REMOVE ALL BURRS.
 2. SURFACE FINISH AS MOLDED.
 3. ALL RADII TO BE .031" MAX, UNLESS NOTED.
 4. ALL DRAFT ANGLES TO BE 1° MAX, UNLESS NOTED.
 5. USE THE SAME MOLD AS FOR DWG # 0000368 OR SAP # 2110663 OR ALLTECH # *32232.

CONFIDENTIAL:		GRACE Davison		GRACE Davison Discovery Sciences 2051 Waukegan Road, Deerfield, IL 60015 (847) 948-8600	
This drawing is the property of Alltech Associates, Inc. Any reproductions or modifications of this drawing or its contents without consent of Alltech is prohibited.					
DESCRIPTION: Short Fingertight No-Slip Fit					
MATERIAL: PEEK				P/N: 2110670	
DRAWNDVK		APPROVED:SPS		DATE: 03/26/14	
GENERAL TOLERANCES DECIMAL: .XX ±.010"; .XXX ±.005" FRACTIONAL: ± 1/64" ANGULAR: ±1/2° UNLESS OTHERWISE SPECIFIED		SCALE: 1 = 1 SIZE B		DRAWING NO: 0001339	
63/				REV C	SHEET 1 OF 1